

Non-destructive testing of steel tubes —

**Part 1: Automatic electromagnetic
testing of seamless and welded (except
submerged arc welded) ferromagnetic
steel tubes for verification of hydraulic
leak-tightness**

The European Standard EN 10246-1:1996 has the status of a
British Standard

ICS 23.040.10

Committees responsible for this British Standard

The preparation of this British Standard was entrusted to Technical Committee ISE/73, Steels for pressure purposes, upon which the following bodies were represented:

Associated Offices Technical Committee
 BEAMA Ltd.
 British Compressed Air Society
 British Forging Industry Association
 British Gas plc
 British Steel Industry
 Electricity Supply Industry in England and Wales
 Engineering Equipment and Materials Users' Association
 Lloyd's Register of Shipping
 Power Generation Contractors' Association (BEAMA Ltd.)
 Process Plant Association
 The Welding Institute
 Co-opted members

The following bodies were also represented in the drafting of the standard, through subcommittees and panels:

British Fluid Power Association
 British Gas
 British Stainless Steel Association
 British Welded Steel Tube Association
 Confederation of British Industry
 Electricity Association
 Energy Industries Council
 Seamless Steel Tube Association

This British Standard, having been prepared under the direction of the Engineering Sector Board, was published under the authority of the Standards Board and comes into effect on 15 July 1996

© BSI 02-1999

The following BSI references relate to the work on this standard:
 Committee reference ISE/73
 Draft for comment 91/37502 DC

ISBN 0 580 25880 7

Amendments issued since publication

Amd. No.	Date	Comments

Contents

	Page
Committees responsible	Inside front cover
National foreword	ii
Foreword	2
Text of EN 10246-1	3
List of references	Inside back cover

National foreword

This British Standard has been prepared by Technical Committee ISE/73 and is the English language version of EN 10246-1:1996, published by the European Committee for Standardization (CEN).

This British Standard contains elements of BS 3889 *Non-destructive testing of pipes and tubes — Part 2A:1986 Automatic eddy current testing of wrought steel tubes*. A complete list of the Parts of EN 10246 is given in Annex A of this standard. When all relevant Parts have been published, BS 3889-2A:1986 will be withdrawn.

Cross-references

Publication referred to	Corresponding British Standard
ISO 235:1980	BS 328 <i>Drills and reamers</i> Part 1:1993 <i>Specification for twist drills</i>
EN 20286-2:1993	BS EN 20286 <i>ISO system of limits and fits</i> Part 2:1993 <i>Tables of standard tolerance grades and limit deviations for holes and shafts</i>

A British Standard does not purport to include all the necessary provisions of a contract. Users of British Standards are responsible for their correct application.

Compliance with a British Standard does not of itself confer immunity from legal obligations.

Summary of pages

This document comprises a front cover, an inside front cover, pages i and ii, the EN title page, pages 2 to 12, an inside back cover and a back cover.

This standard has been updated (see copyright date) and may have had amendments incorporated. This will be indicated in the amendment table on the inside front cover.

EUROPEAN STANDARD

EN 10246-1

NORME EUROPÉENNE

EUROPÄISCHE NORM

March 1996

ICS 23.040.10

Descriptors: Metal tubes, steel tubes, welded tubes, seamless tubes, non-destructive tests, electromagnetic tests, inspection, leak-tightness

English version

Non-destructive testing of steel tubes — Part 1: Automatic electromagnetic testing of seamless and welded (except submerged arc-welded) ferromagnetic steel tubes for verification of hydraulic leak-tightness

Essais non destructifs des tubes en acier —
Partie 1: Contrôle automatique
électromagnétique pour vérification de
l'étanchéité hydraulique des tubes en acier sans
soudure et soudés ferromagnétiques (sauf à
l'arc immergé sous flux en poudre)

Zerstörungsfreie Prüfung von Stahlrohren —
Teil 1: Automatische elektromagnetische
Prüfung nahtloser und geschweißter
(ausgenommen unterpulvergeschweißter)
ferromagnetischer Stahlrohre zum Nachweis
der Dichtigkeit

This European Standard was approved by CEN on 1995-12-28. CEN members are bound to comply with the CEN/CENELEC Internal Regulations which stipulate the conditions for giving this European Standard the status of a national standard without any alteration.

Up-to-date lists and bibliographical references concerning such national standards may be obtained on application to the Central Secretariat or to any CEN member.

This European Standard exists in three official versions (English, French, German). A version in any other language made by translation under the responsibility of a CEN member into its own language and notified to the Central Secretariat has the same status as the official versions.

CEN members are the national standards bodies of Austria, Belgium, Denmark, Finland, France, Germany, Greece, Iceland, Ireland, Italy, Luxembourg, Netherlands, Norway, Portugal, Spain, Sweden, Switzerland and United Kingdom.

CEN

European Committee for Standardization
Comité Européen de Normalisation
Europäisches Komitee für Normung

Central Secretariat: rue de Stassart 36, B-1050 Brussels

Foreword

This European Standard has been prepared by the Technical Committee ECISS/TC29, Steel tubes and fittings for steel tubes, the secretariat of which is held by UNI.

This European Standard shall be given the status of a national standard, either by publication of an identical text or by endorsement, at the latest by September 1996, and conflicting standards shall be withdrawn at the latest by September 1996.

According to the CEN/CENELEC Internal Rules, the national standards organizations of the following countries are bound to implement this European Standard: Austria, Belgium, Denmark, Finland, France, Germany, Greece, Iceland, Ireland, Italy, Luxembourg, Netherlands, Norway, Portugal, Spain, Sweden, Switzerland and United Kingdom.

Contents

	Page
Foreword	2
1 Scope	3
2 Normative references	3
3 General requirements	3
4 Method of test	3
5 Reference standards	4
6 Dimensions of reference notch	8
7 Equipment calibration and checking	9
8 Acceptance	9
9 Test reporting	10
Annex A (informative) Table of Parts of EN 10246 <i>Non-destructive testing of steel tubes</i>	11
Annex B (informative) Guidance notes on limitations associated with eddy current and flux leakage test methods	12
Figure 1 — Simplified diagram of eddy current concentric coil technique	4
Figure 2 — Simplified diagram of rotating tube/pancake coil eddy current technique (helical scan)	5
Figure 3 — Simplified diagram of rotating magnetic transducer/tube flux leakage technique	6
Figure 4 — Simplified diagram of typical magnetic transducer/tube flux leakage technique	7
Figure 5 — “N” type notch	8
Figure 6 — Transverse notch-forms	8
Table 1 — Tube diameter related drill sizes to produce the reference holes	7

1 Scope

This Part of EN 10246 specifies the requirements for automatic electromagnetic testing of seamless and welded ferromagnetic steel tubes, with the exception of submerged arc-welded (SAW) tubes, for verification of hydraulic leak-tightness.

This Part of EN 10246 is applicable to the inspection of tubes with an outside diameter greater than or equal to 4 mm.

For automatic eddy current testing of seamless and welded austenitic and austenitic-ferritic steel tubes (excluding SAW tubes), for verification of hydraulic leak-tightness, EN 10246-2 applies.

European Standard EN 10246 *Non-destructive testing of steel tubes* comprises the Parts shown in Annex A.

2 Normative references

This Part of EN 10246 incorporates by dated or undated reference, provisions from other publications. These normative references are cited at the appropriate places in the text and the publications are listed hereafter. For dated references, subsequent amendments to or revisions of any of those publications apply to this Part of EN 10246, only when incorporated in it by amendment or revision. For undated references the latest edition of the publication referred to applies.

EN 20286-2, *ISO system of limits and fits — Part 2: Tables of standard tolerance grades and limit deviations for holes and shafts*.

ENV 10220, *Plain end steel tubes, welded and seamless — General tables of dimensions and masses per unit length*.

ISO 235, *Parallel shank jobber and stub series drills and Morse taper shank drills*.

3 General requirements

3.1 The electromagnetic inspection covered by this Part of EN 10246 is usually carried out on tubes after completion of all the primary production process operations.

This inspection shall be carried out by suitably trained, qualified and competent NDT personnel approved by the manufacturer.

3.2 The tubes to be tested shall be sufficiently straight to ensure the validity of the test. The surfaces shall be sufficiently free from foreign matter which would interfere with the validity of the test.

4 Method of test

4.1 Test techniques

4.1.1 The tubes shall be tested for verification of hydraulic leak-tightness by either the eddy current method or flux leakage method using one of the following techniques.

- a) Concentric coil (eddy current method) — see Figure 1.
- b) Rotating tube/pancake coil (eddy current method) — see Figure 2.
- c) Rotating tube/magnetic transducer (flux leakage method) — see Figure 3.
- d) Multiple concentric magnetic transducers (flux leakage method) — see Figure 4.

NOTE 1 It is recognized that there may be, as in the case of hydraulic testing under normal production conditions, a short length at both tube ends which cannot be tested.

NOTE 2 For guidelines on the limitations of the eddy current and flux leakage test methods, see Annex B.

4.1.2 When testing seamless or welded tubes using the eddy current concentric coil technique, the maximum outside diameter tube to be tested is restricted to 177,8 mm.

NOTE Square or rectangular tubes, used for structural purposes, with a maximum dimension across the diagonal of 177,8 mm may also be tested using this technique.

4.1.3 When testing seamless or welded tubes using the rotating tube/pancake coil eddy current technique or rotating tube/magnetic transducer flux leakage technique, the tube and the pancake coils/magnetic transducers shall be moved relative to each other so that the whole of the tube surface is scanned. The chosen relative speed of movement during testing shall not vary by more than $\pm 10\%$. There is no restriction on the maximum outside diameter using these techniques.

4.1.4 When testing seamless and welded tubes using the multiple concentric magnetic transducer technique, the tube and the multiple transducer assembly shall be linearly moved relative to each other so that the whole of the tube surface is scanned. There is no restriction on the maximum outside diameter using this technique.

4.2 Test equipment

The equipment shall be capable of classifying tubes as either acceptable or suspect by means of an automatic trigger/alarm level combined with a marking and/or sorting system.

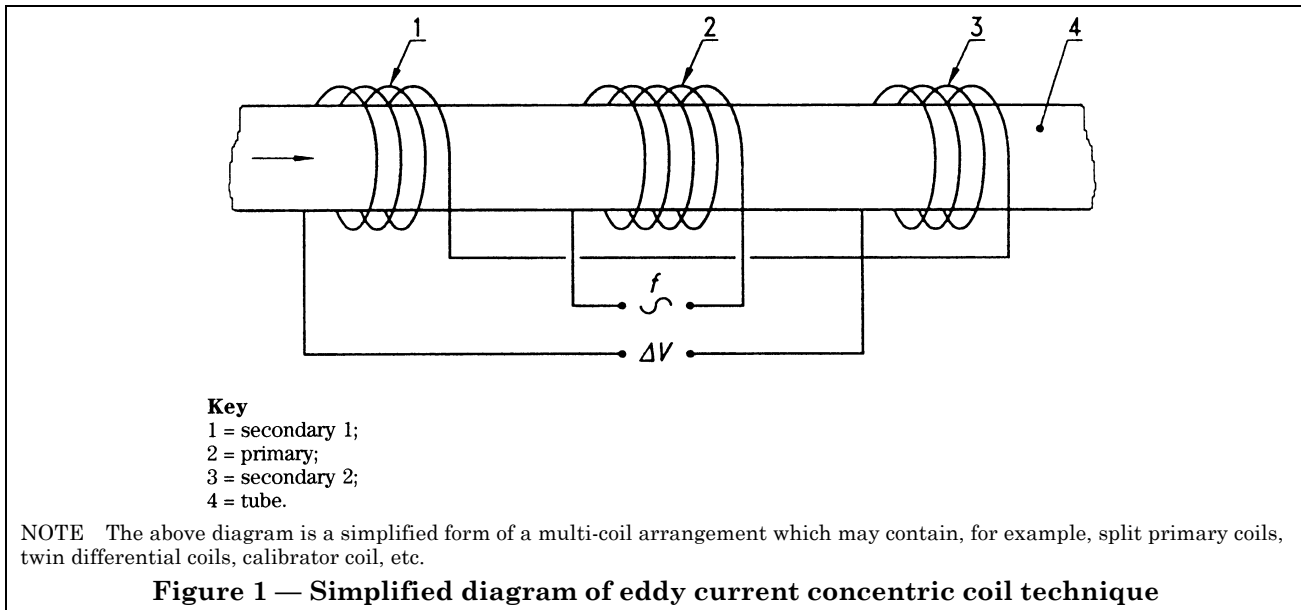

5 Reference standards

5.1 General

5.1.1 The reference standards defined in this Part of EN 10246 are convenient standards for the calibration of non-destructive testing equipment. The dimensions of these standards should not be construed as the minimum size of imperfection detectable by such equipment.

5.1.2 The testing equipment shall be calibrated using reference standards introduced into a tubular test piece. The test piece shall be of the same specified diameter, thickness and surface finish as the tube to be tested and shall have similar electromagnetic properties.

NOTE In special cases, for example testing hot tubes or using equipment contained within a continuous tube mill, a modified calibration or calibration checking procedure can be used, by agreement.

5.1.3 The reference standards for the various testing techniques shall be as follows:

- a) a reference hole or holes as defined in 5.2 when using the eddy current concentric coil technique;
- b) a reference notch as defined in 5.3 when using the rotating tube/pancake coil eddy current technique or the rotating tube/magnetic transducer flux leakage technique;

- c) a reference notch (or equivalent hole) as defined in 5.4 when using the multiple concentric magnetic transducer flux leakage technique.

5.2 Eddy current concentric coil technique

When using the eddy current concentric coil technique, the test piece shall contain three circular holes, drilled radially through the full thickness of the test piece. The three holes shall be circumferentially displaced 120° from each other, and shall be sufficiently separated longitudinally and from the extremities of the test piece so that clearly distinguishable signal indications are obtained.

Alternatively, only one hole shall be drilled through the full thickness of the test piece and during calibration and calibration checking the test piece shall be passed through the equipment with the hole positioned at 0°, 90°, 180° and 270°.

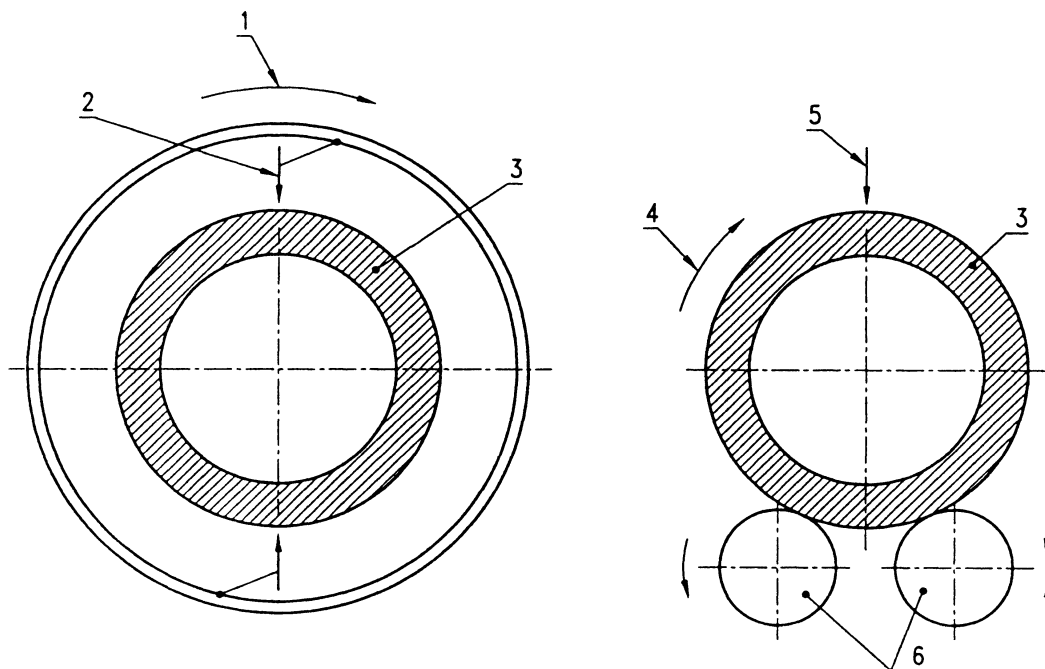

a) Rotating pancake coil technique (linear movement through rotating pancake coil assembly)

b) Rotating tube technique (linear pancake coil traverse along the tube length or fixed coils during helical movement of tube)

Key

- 1 = pancake coil rotation;
- 2 = pancake coil(s);
- 3 = tube;
- 4 = tube rotation;
- 5 = fixed pancake coil(s);
- 6 = turning rolls.

NOTE The pancake coils used in a) and b) above take many forms, for example, single coil, multi-coil of various configurations, depending on the equipment used and other factors.

Figure 2 — Simplified diagram of rotating tube/pancake coil eddy current technique (helical scan)

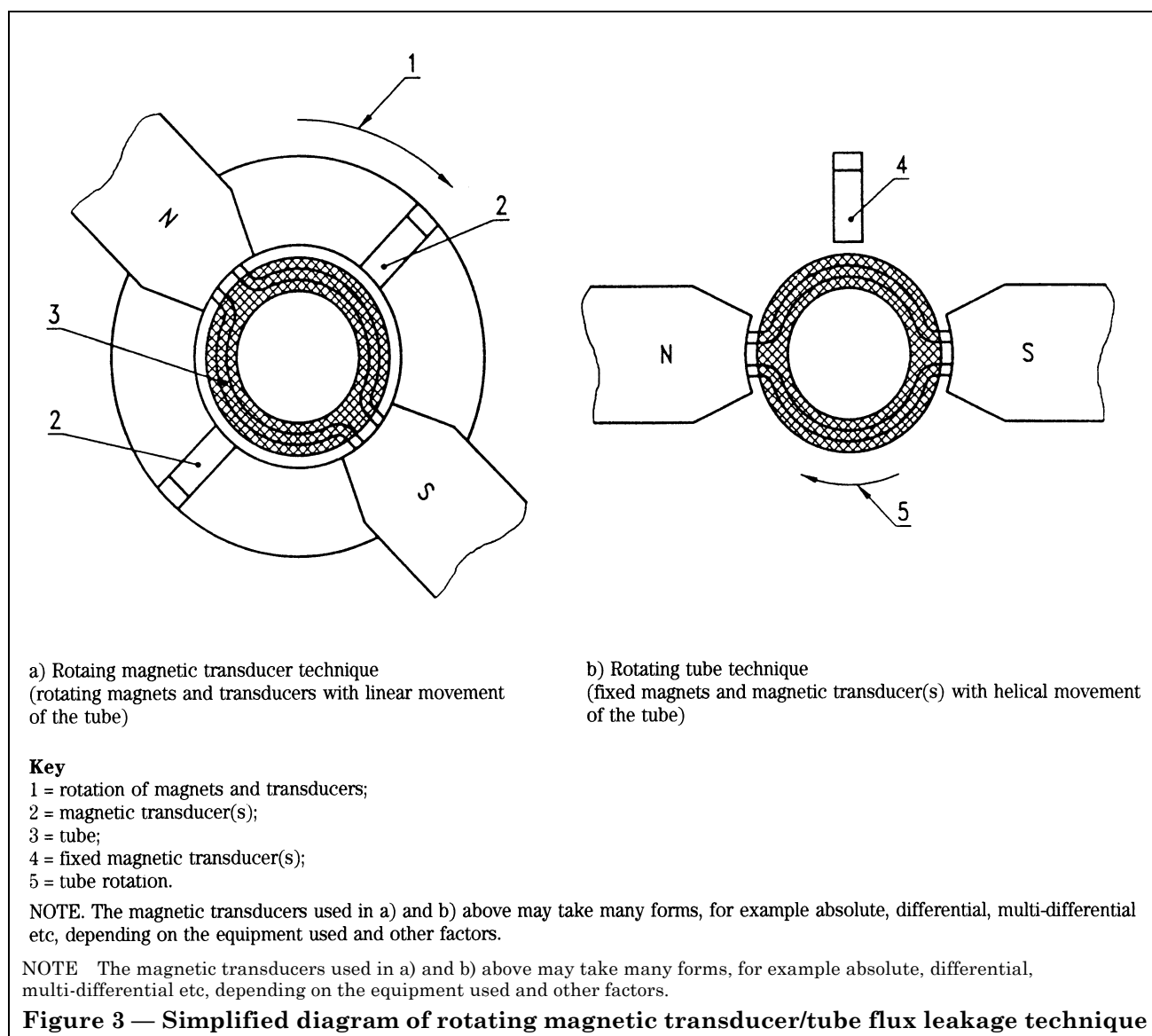

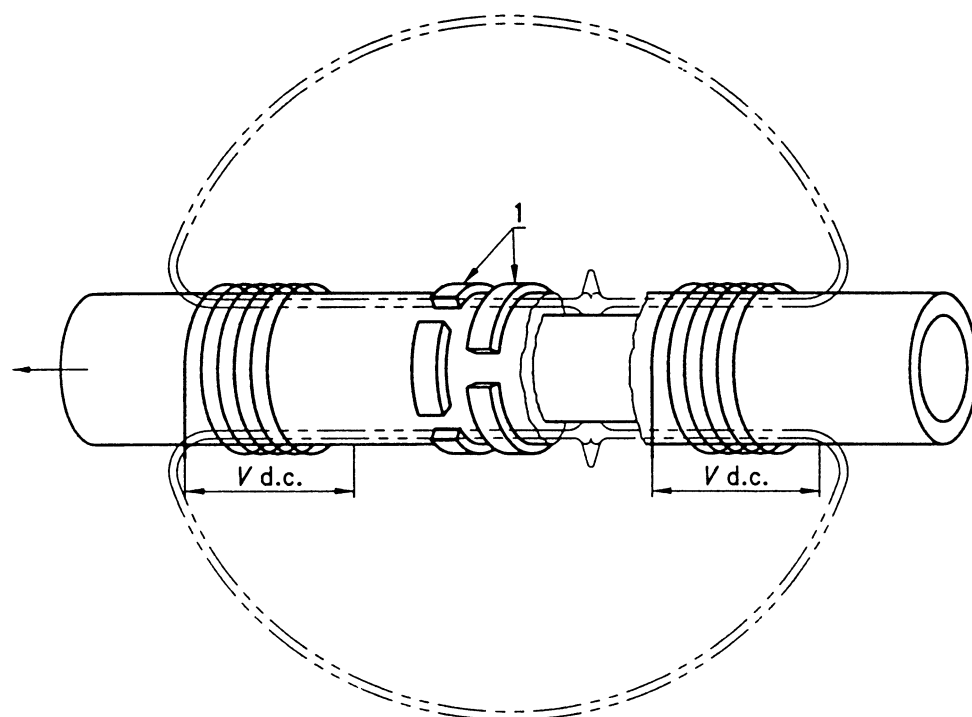

Key
1 = staggered array of transducers.

NOTE The magnetic transducer may take different forms, for example absolute, differential etc., depending on the equipment used and other factors. The means of introducing magnetic flux in a direction parallel to the major axis of the tube can be achieved by methods other than that shown above.

Figure 4 — Simplified diagram of typical magnetic transducer/flux leakage technique

The diameter of the drill required to produce these holes depends on the tube outside diameter as shown in Table 1.

The diameter of the reference hole or reference holes shall be verified and shall not exceed the specified drill diameter by more than 0,2 mm.

Table 1 — Tube diameter related drill sizes to produce the reference holes

Tube outside diameter D^a mm	Drill diameter ^b mm
$D \leq 26,9$	1,20
$26,9 < D \leq 48,3$	1,70
$48,3 < D \leq 63,5$	2,20
$63,5 < D \leq 114,3$	2,70
$114,3 < D \leq 139,7$	3,20
$139,7 < D \leq 177,8$	3,70

^a See ENV 10220.
^b Tolerances according to ISO 235 (jobber series) and EN 20286-2 (h8).

5.3 Eddy current/flux leakage — rotating techniques

5.3.1 When using the rotating tube/pancake coil eddy current technique, or rotating tube/magnetic transducer flux leakage technique, the test piece shall contain a longitudinal reference notch on the external surface.

5.3.2 The reference notch shall be sufficiently separated from the extremities of the test piece, so that a clearly distinguishable signal indication is obtained.

5.3.3 The reference notch shall be of the “N” type (see Figure 5) and shall lie parallel to the major axis of the tube. The sides shall be nominally parallel and the bottom shall be nominally square to the sides.

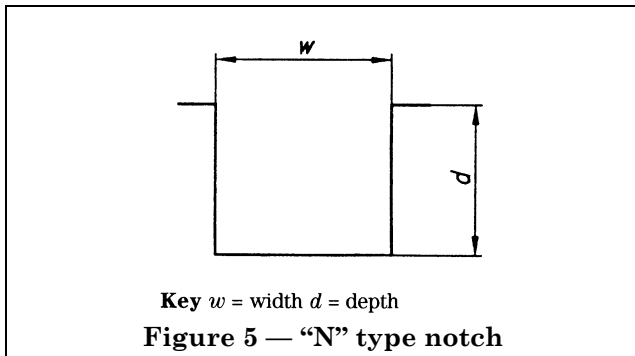

5.3.4 The reference notch shall be formed by machining, spark erosion or other methods.

NOTE It is recognized that the bottom or the bottom corners of the notch may be rounded.

5.4 Flux leakage — multiple transducer technique

5.4.1 When using the multiple magnetic transducer flux leakage technique, the test piece shall contain a transverse reference notch on the external surface or, by agreement, a reference hole drilled radially through the full thickness of the test piece.

In the case of the reference hole or holes, the diameter of the drill required to produce the reference hole(s) shall be agreed between purchaser and manufacturer. The manufacturer shall demonstrate that the test sensitivity achieved using the reference hole(s) and the equipment settings, for example signal rate filtering etc., is essentially equivalent to that obtained when using the reference notch.

5.4.2 The reference notch or the reference hole(s) shall be sufficiently separated from the extremities of the test piece, and from each other in the case of multiple reference holes, so that (a) clearly distinguishable signal indication(s) is (are) obtained.

5.4.3 The reference notch shall be of the “N” type (see Figure 5) and shall lie at right angles to the major axis of the tube, and one of the notch forms as shown in Figure 6 shall be used, at the discretion of the manufacturer.

5.4.4 The reference notch shall be formed by machining, spark erosion or other methods, and the sides shall be nominally parallel and the bottom shall be nominally square to the sides.

NOTE It is recognized that the bottom or bottom corners of the notch may be rounded.

5.4.5 The diameter of the reference hole(s), when used, shall be verified and shall not exceed the agreed drill diameter by more than 0,2 mm.

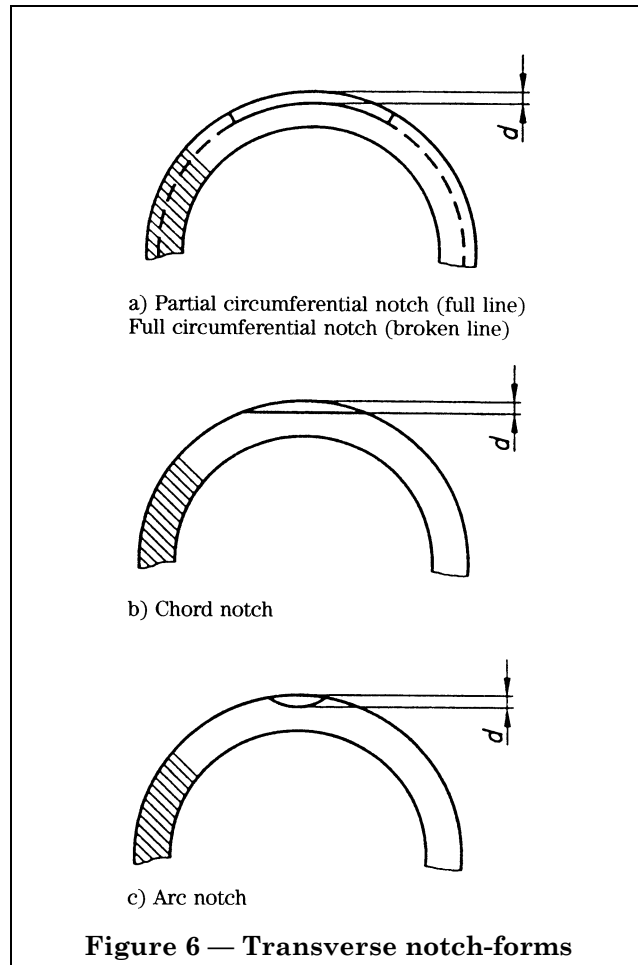

6 Dimensions of reference notch

The dimensions of the reference notch shall be as follows:

6.1 Width, w (see Figure 5)

The width of the reference notch shall be not greater than the reference notch depth.

6.2 Depth, d (see Figure 5)

The depth of the reference notch shall be 12,5 % of the specified thickness with the following limitations:

- minimum depth: 0,5 mm
- maximum depth: 1,5 mm.

6.3 Tolerance on depth

The tolerance on depth shall be ± 15 % of reference notch depth.

6.4 Length

The length of the reference notch shall be twice the width of each individual transducer, with a minimum of 50 mm.

6.5 Verification

The reference notch dimensions and shape shall be verified by a suitable technique.

7 Equipment calibration and checking

7.1 The equipment shall be adjusted to consistently produce (for example, from three consecutive passes of the test piece through the equipment) clearly identifiable signals from the reference standard(s). These signals shall be used to set the trigger/alarm level of the equipment.

When using multiple reference holes in the test piece (eddy current concentric coil technique), the full amplitude obtained from the reference hole giving the smallest signal shall be used to set the trigger/alarm level of the equipment. When using a single reference hole in the test piece, the test piece shall be passed through the inspection equipment with the reference hole, on successive runs, positioned at 0°, 90°, 180° and 270° and the full amplitude of the smallest signal obtained from the reference hole shall be used to set the trigger/alarm level of the equipment.

When using the reference notch (rotating tube/pancake coil eddy current technique or rotating tube/magnetic transducer flux leakage technique), the full signal amplitude shall be used to set the trigger/alarm level of the equipment.

When using the full circumferential reference notch (multiple transducer flux leakage technique), the full signal amplitude obtained on each magnetic transducer channel shall be used to set the trigger/alarm level on each channel of the equipment.

When using the partial circumferential, chord or arc reference notch or the reference hole (multiple transducer flux leakage technique), the test piece shall be passed through the inspection equipment with the reference notch or hole, on successive runs, positioned at the angular pitch of adjacent magnetic transducers, such that the centre of the reference notch or hole passes past the centre line of each transducer in turn. The full signal amplitude obtained from each transducer shall be used to set the trigger/alarm level on that transducer channel of the equipment.

7.2 During calibration, the relative speed of movement between the test piece and the test coils shall be the same as that to be used during the production test (see also 5.1.2 note). The same equipment settings, for example frequency, sensitivity, phase discrimination, rate filtering, magnetic saturation, etc., shall be employed.

7.3 The calibration of the equipment shall be checked at regular intervals during the production testing of tubes of the same specified diameter, thickness and grade, by passing the test piece through the inspection equipment.

The frequency of checking the calibration shall be at least every 4 h, but also whenever there is an equipment operator changeover and at the start and end of the production run.

NOTE In cases where a production testing run is continuous from one shift period to the next, the 4 h maximum period may be extended by agreement between purchaser and manufacturer.

7.4 The equipment shall be recalibrated if any of the parameters which were used during the initial calibration are changed.

7.5 If on checking during production testing, the calibration requirements are not satisfied, even after increasing the test sensitivity by 3 dB to allow for system drift, then all tubes tested since the previous equipment check shall be retested after the equipment has been recalibrated.

Retesting shall not be necessary even after a drop in test sensitivity of more than 3 dB but less than 6 dB since the previous equipment calibration, provided that suitable recordings from individually identifiable tubes are available which permit accurate classification as either suspect or acceptable.

8 Acceptance

8.1 Any tube producing signals lower than the trigger/alarm level shall be deemed to have passed this test.

8.2 Any tube producing signals equal to or greater than the trigger/alarm level shall be designated suspect or, at the manufacturer's option, may be retested as specified above.

8.3 If on retesting no signal is obtained equal to or greater than the trigger/alarm level, the tube shall be deemed to have passed this test.

Tubes giving signals equal to or greater than the trigger/alarm level shall be designated suspect.

8.4 For suspect tubes, one or more of the following actions shall be taken, subject to the requirements of the product standard.

- a) The suspect area shall be explored by dressing using an acceptable method. After checking that the remaining thickness is within tolerance, the tube shall be tested as previously specified. If no signals are obtained equal to or greater than the trigger/alarm level, the tube shall be deemed to have passed this test.

The suspect area may be retested by other non-destructive techniques and test methods, by agreement between purchaser and manufacturer to agreed acceptance levels.

b) Each suspect tube shall be subjected to a hydraulic leak-tightness test in accordance with the relevant product standard, unless otherwise agreed between the purchaser and manufacturer.

c) The suspect area shall be cropped off. The manufacturer shall ensure to the satisfaction of the purchaser that all the suspect area has been removed.

d) The tube shall be deemed not to have passed the test.

9 Test reporting

When specified, the manufacturer shall provide the purchaser with, at least, the following information:

- a) reference to this Part of EN 10246;
- b) date of test;
- c) statement of conformity;
- d) product designation by grade and size;
- e) type and details of inspection technique;
- f) description of the reference standard.

Annex A (informative)

Table of Parts of EN 10246 *Non-destructive testing of steel tubes*

Purpose of test	Title of part	Part no.	ISO ref.
Leak tightness	<i>Automatic electromagnetic testing of seamless and welded (except submerged arc-welded) ferromagnetic steel tubes for verification of hydraulic leak-tightness</i>	Part 1	9302
	<i>Automatic eddy current testing of seamless and welded (except submerged arc-welded) austenitic and austenitic-ferritic steel tubes for verification of hydraulic leak-tightness</i>	Part 2	—
Longitudinal and/or transverse imperfections	<i>Automatic eddy current testing of seamless and welded (except submerged arc-welded) steel tubes for the detection of imperfections</i>	Part 3	9304
	<i>Automatic full peripheral magnetic transducer/flux leakage testing of seamless ferromagnetic steel tubes for the detection of transverse imperfections</i>	Part 4	9598
	<i>Automatic full peripheral magnetic transducer/flux leakage testing of seamless and welded (except submerged arc-welded) ferromagnetic steel tubes for the detection of longitudinal imperfections</i>	Part 5	9402
	<i>Automatic full peripheral ultrasonic testing of seamless steel tubes for the detection of transverse imperfections</i>	Part 6	9305
	<i>Automatic full peripheral ultrasonic testing of seamless and welded (except submerged arc-welded) steel tubes for the detection of longitudinal imperfections</i>	Part 7	9303
	<i>Automatic ultrasonic testing of the weld seam of electric resistance and induction welded steel tubes for the detection of longitudinal imperfections</i>	Part 8	9764
	<i>Automatic ultrasonic testing of the weld seam of submerged arc-welded steel tubes for the detection of longitudinal and/or transverse imperfections</i>	Part 9	9765
	<i>Radiographic testing of the weld seam of submerged arc-welded steel tubes for the detection of imperfections</i>	Part 10	12096
Surface imperfections	<i>Liquid penetrant testing of seamless and welded steel tubes for the detection of surface imperfections</i>	Part 11	12095
	<i>Magnetic particle inspection of the tube body of seamless and welded ferromagnetic steel tubes for the detection of surface imperfections</i>	Part 12	13665
Thickness	<i>Automatic full peripheral ultrasonic thickness testing of seamless and welded (except submerged arc-welded) steel tubes</i>	Part 13	10543
Laminar imperfections	<i>Automatic full peripheral ultrasonic testing of seamless and welded (except submerged arc-welded) steel tubes for the detection of laminar imperfections</i>	Part 14	10124
	<i>Automatic ultrasonic testing of strip/plate used in the manufacture of welded steel tubes for the detection of laminar imperfections</i>	Part 15	12094
	<i>Automatic ultrasonic testing of the areas adjacent to the weld seam of welded steel tubes for the detection of laminar imperfections</i>	Part 16	13663
	<i>Ultrasonic testing of the tube ends of seamless and welded steel tubes for the detection of laminar imperfections</i>	Part 17	11496
	<i>Magnetic particle inspection of the tube ends of seamless and welded ferromagnetic steel tubes for the detection of laminar imperfections</i>	Part 18	13664

Annex B (informative)

Guidance notes on limitations associated with eddy current and flux leakage test methods

B.1 Eddy current testing

B.1.1 General

It should be noted that during the eddy current testing of tubes, the sensitivity of the test is at a maximum at the tube surface adjacent to the test coil and decreases with increasing distance from the test coil. The signal response from a subsurface or internal surface imperfection is thus smaller than that from an external surface imperfection of the same size. The capability of the test equipment to detect subsurface or internal surface imperfections is determined by various factors but predominantly by the thickness of the tube under test and the eddy current excitation frequency.

The excitation frequency applied to the test coil determines the extent to which the induced eddy current intensity penetrates into the tube wall. The higher the excitation frequency the lower the penetration and conversely the lower the excitation frequency the higher the penetration; particular account should be taken of tube physical parameters (e.g. conductivity, permeability, etc.).

B.1.2 Concentric coil technique

This test technique is preferred since it can detect short longitudinal imperfections and transverse imperfections, both of which break, or lie below, the surface adjacent to the test coil.

The maximum length of the longitudinal imperfection which is detectable is principally determined by the search coil arrangement and by the rate of change of section along the length of the imperfection.

B.1.3 Pancake coil technique

This test technique utilizes one or more pancake coils to describe a helical path over the tube surface. For this reason the technique detects longitudinal imperfections having a minimum length dependent of the width of the test coil and the inspection helical pitch. It is recognized that transverse imperfections are not normally detectable.

Since the excitation frequency is significantly higher than that using concentric coils, only imperfections which break the surface adjacent to the test coil are detectable.

B.2 Magnetic transducer/flux leakage testing

B.2.1 General

It should be noted that during the magnetic transducer/flux leakage testing of tubes, the sensitivity of the test is at a maximum at the tube surface adjacent to the magnetic transducer and decreases with increasing tube thickness due to effective diminishing flux diversion from imperfections at the tube bore surface in relation to that at the external surface. The signal response from internal surface imperfections may thus be smaller than that from an external imperfection of the same size.

B.2.2 Rotating tube/magnetic transducer technique

This test technique utilizes one or more magnetic transducers to describe a helical path over the tube surface. For this reason the technique detects longitudinal imperfections having a minimum length dependent on the width of the transducer and the inspection helical pitch. It is recognized that transverse imperfections are not normally detectable.

B.2.3 Multiple transducer technique

This test technique utilizes a multiplicity of magnetic transducers surrounding the tube through which the tube is passed with a linear motion. For this reason the technique detects predominantly transverse imperfections having a minimum length dependent on the circumferential dimension of the transducer. It is recognized that longitudinal imperfections are not normally detectable unless they have a transverse component (oblique).

List of references

See national foreword.

BSI — British Standards Institution

BSI is the independent national body responsible for preparing British Standards. It presents the UK view on standards in Europe and at the international level. It is incorporated by Royal Charter.

Revisions

British Standards are updated by amendment or revision. Users of British Standards should make sure that they possess the latest amendments or editions.

It is the constant aim of BSI to improve the quality of our products and services. We would be grateful if anyone finding an inaccuracy or ambiguity while using this British Standard would inform the Secretary of the technical committee responsible, the identity of which can be found on the inside front cover. Tel: 020 8996 9000. Fax: 020 8996 7400.

BSI offers members an individual updating service called PLUS which ensures that subscribers automatically receive the latest editions of standards.

Buying standards

Orders for all BSI, international and foreign standards publications should be addressed to Customer Services. Tel: 020 8996 9001. Fax: 020 8996 7001.

In response to orders for international standards, it is BSI policy to supply the BSI implementation of those that have been published as British Standards, unless otherwise requested.

Information on standards

BSI provides a wide range of information on national, European and international standards through its Library and its Technical Help to Exporters Service. Various BSI electronic information services are also available which give details on all its products and services. Contact the Information Centre. Tel: 020 8996 7111. Fax: 020 8996 7048.

Subscribing members of BSI are kept up to date with standards developments and receive substantial discounts on the purchase price of standards. For details of these and other benefits contact Membership Administration. Tel: 020 8996 7002. Fax: 020 8996 7001.

Copyright

Copyright subsists in all BSI publications. BSI also holds the copyright, in the UK, of the publications of the international standardization bodies. Except as permitted under the Copyright, Designs and Patents Act 1988 no extract may be reproduced, stored in a retrieval system or transmitted in any form or by any means – electronic, photocopying, recording or otherwise – without prior written permission from BSI.

This does not preclude the free use, in the course of implementing the standard, of necessary details such as symbols, and size, type or grade designations. If these details are to be used for any other purpose than implementation then the prior written permission of BSI must be obtained.

If permission is granted, the terms may include royalty payments or a licensing agreement. Details and advice can be obtained from the Copyright Manager. Tel: 020 8996 7070.